



CPM-20

Multifunction

Power Meter



CPM-20 Operation Manual

Description

The CPM-20 series Multifunction Power Meter provide high accuracy measurement, display and communication(Modbus RTU) of all electrical and power quality parameters, including harmonic measurement THD(Total Harmonic distortion)

Provides electricity bill ratio (Cost) and CO₂ set can show cumulative electricity bills and carbon emissions, and suitable for the installation in the power management of remote communication, such as the use of demand.

Application

Control panels and Motor, Generator monitoring Switchgear distribution systems , Energy Management Power quality analysis

Front Panel

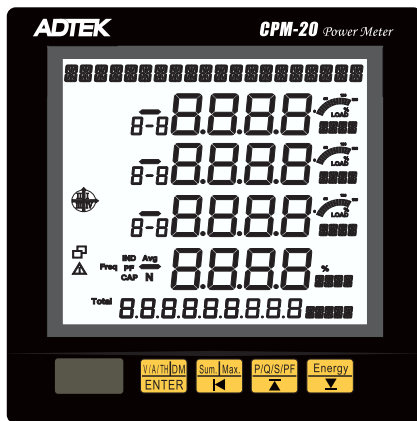

Control button:

- ENTER / Voltage /Current display page
- Shift / Main electric parameters display page
- UP / Electric parameters display page
- Down / Energy parameters display page

Passwords:4 digits passwords ; Range : 0000~9999

Display: LCD 65(W)x61(H)mm ; White backlight ; Blue wording

Visible under direct sunlight

LCD LED: Backlight on time 0~15Min

Upper row 20 digits: Display date. time

8.888: 4 Digitsx 4 rows, Display value

8.88888888: 9 Digits x 1 row, Display Energy parameters

: RS485 communication status ; 2 square status icons
Display Master and Slave status

: Wiring changed

Load status indication: IND: load is inductive CAP: load is capacitive

LOAD%: Display load percentage : Display load quadrant

R - b , b - C , C - R: When on ,value showing Line-Line

R , b , C: When on ,value showing in Phase

N: When on ,value showing in Neutral

Total: When on ,value showing Total value

Avg: When on ,value showing Average

THD: When on ,value showing Total harmonics distortion

.. :LED-16 byte display parameters Unit

Dimensions

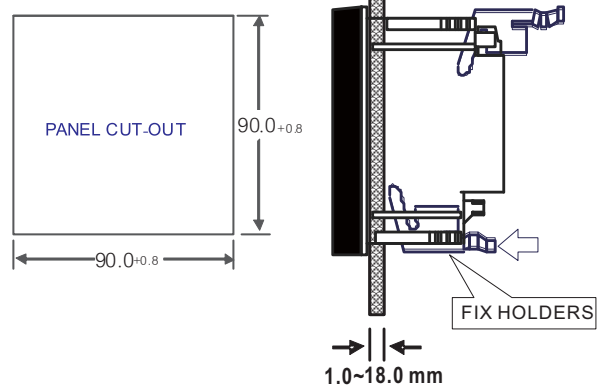
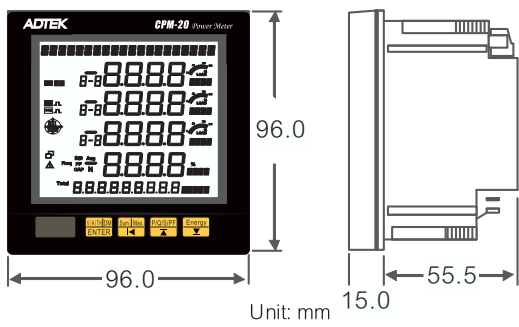

Connection Diagram

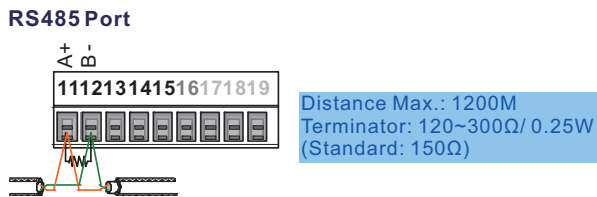
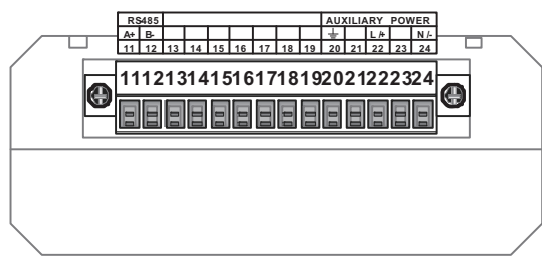
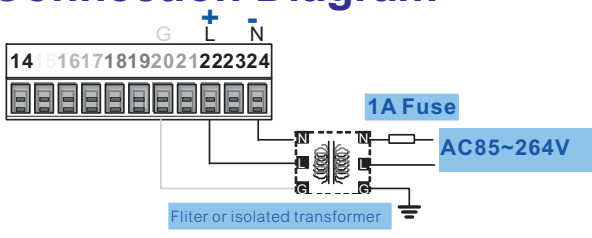

Voltage and Current Wiring (CT secondary side distinguishes 1A/5A and 333mV)

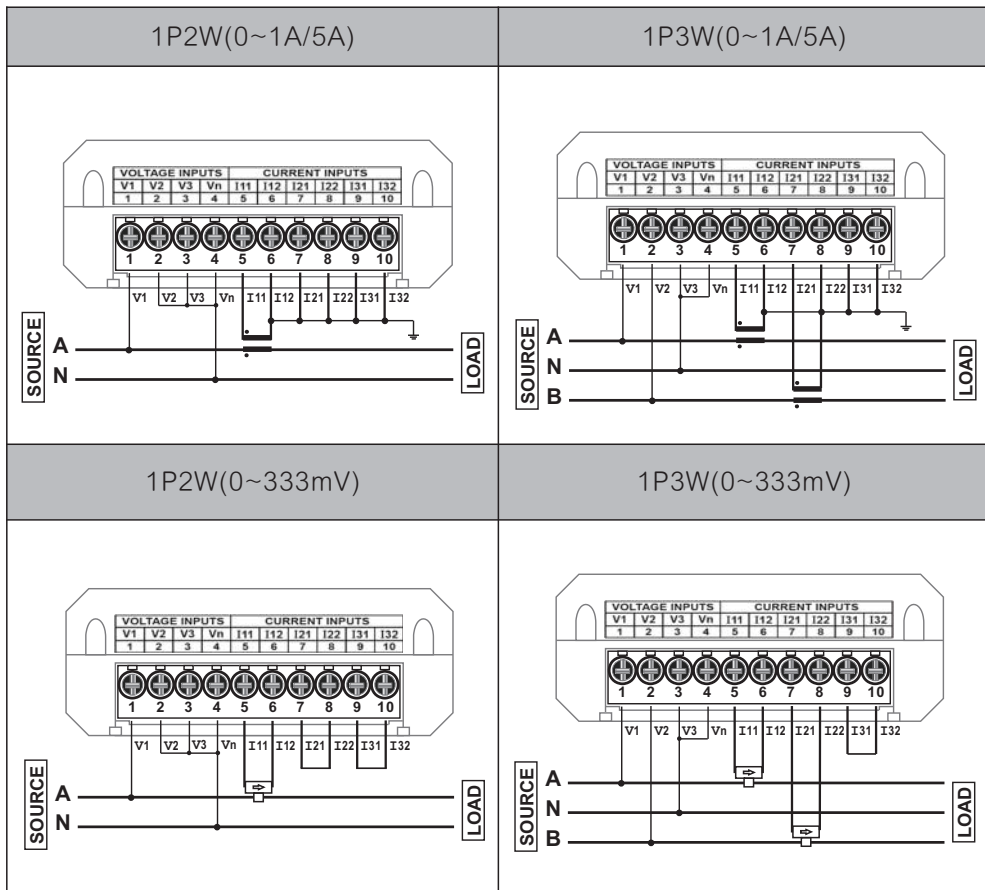

3P3W NO PT

3CT(0~1A/5A)

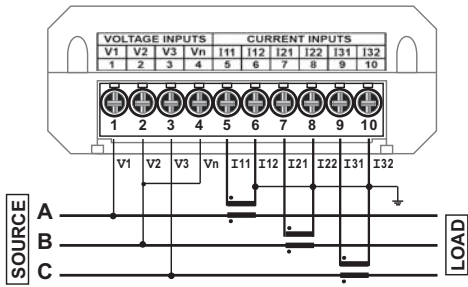

2CT(0~1A/5A)

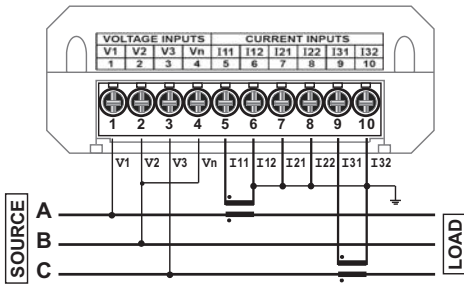

1CT(0~1A/5A)

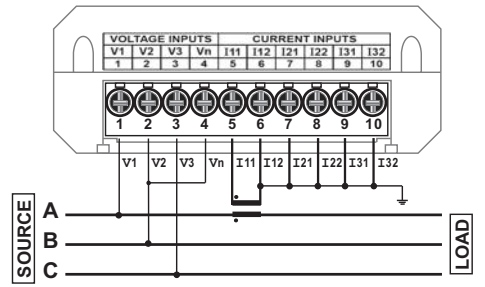

3CT(0~333mV)

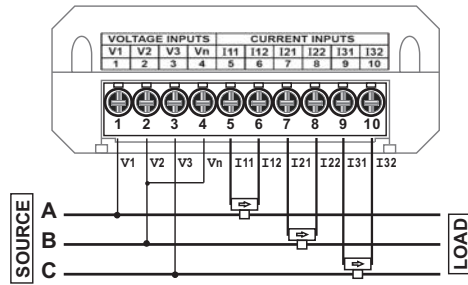

2CT(0~333mV)

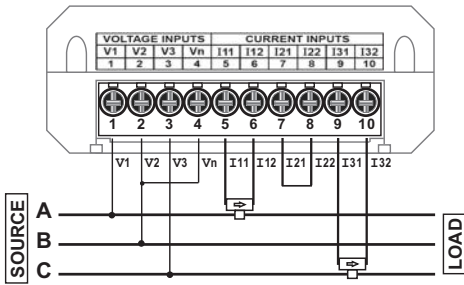

1CT(0~333mV)

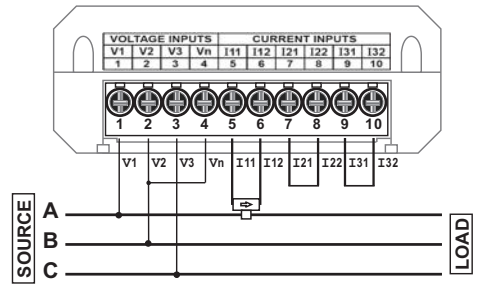

3P3W 2PT

3CT(0~1A/5A)

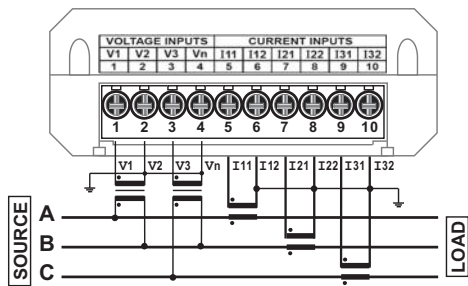

2CT(0~1A/5A)

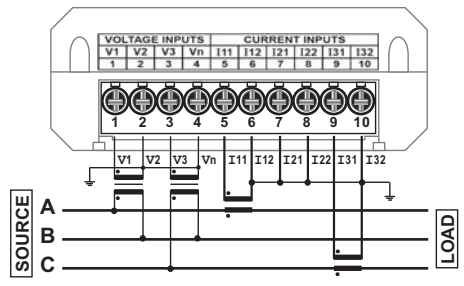

1CT(0~1A/5A)

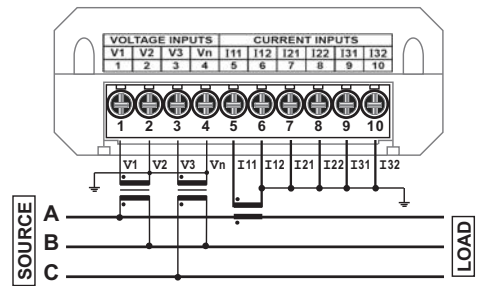

3CT(0~333mV)

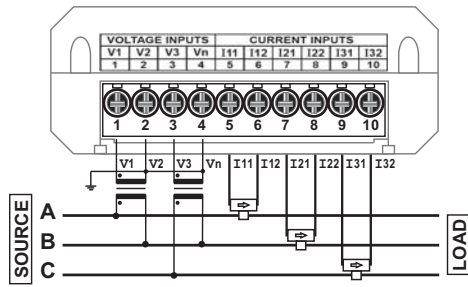

2CT(0~333mV)

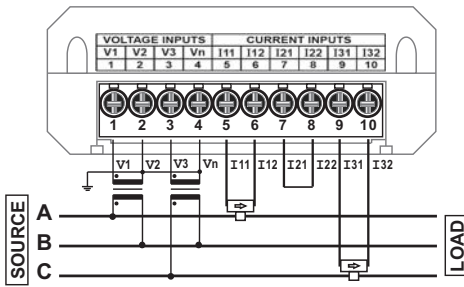

1CT(0~333mV)

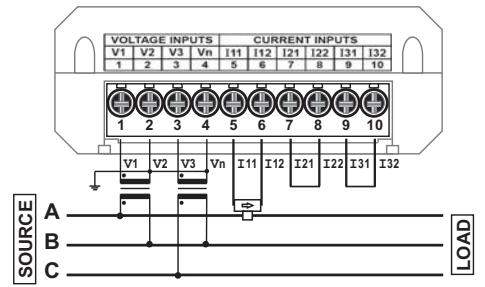

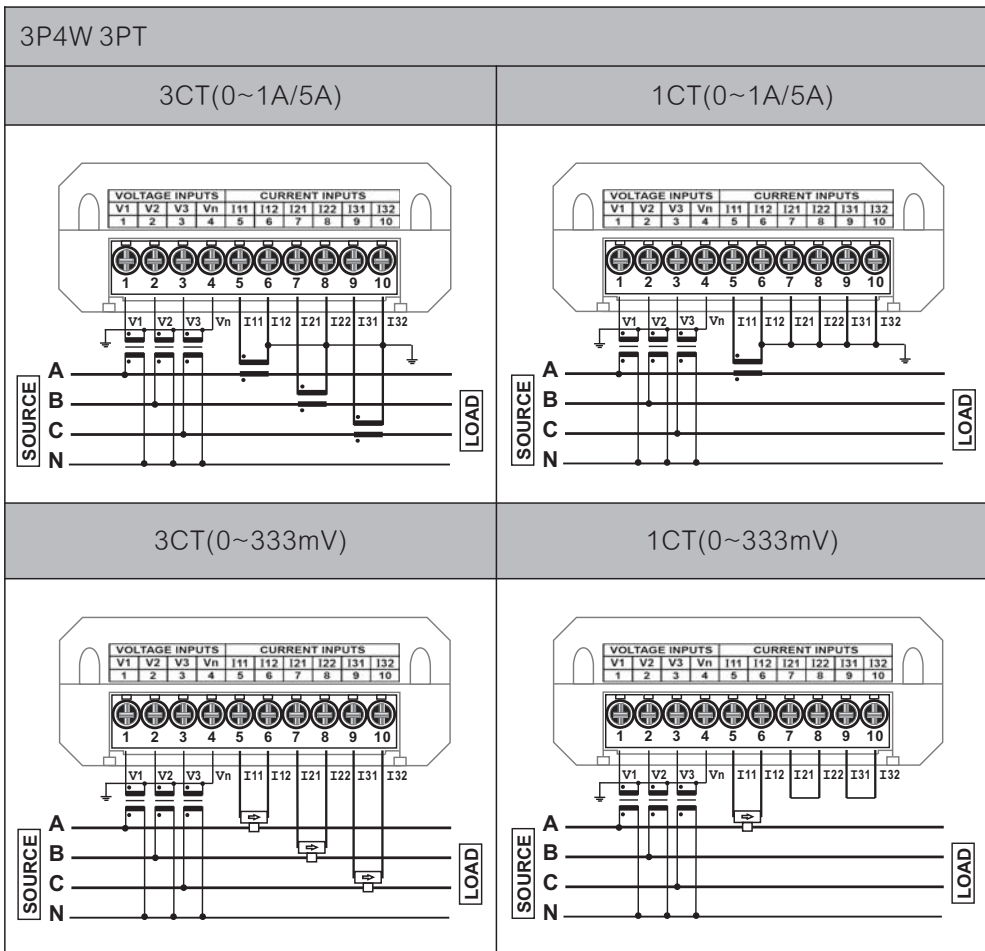
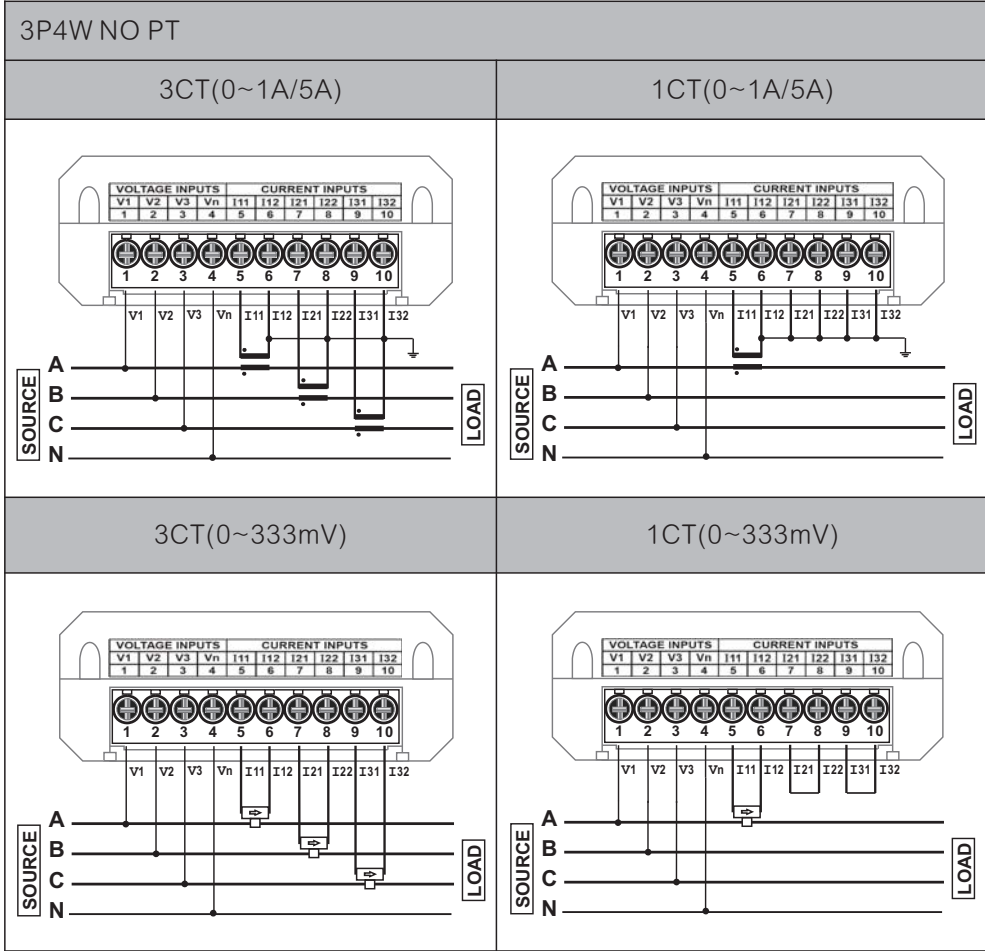

Operational processes

Key definition:



ENTER / Volt.(voltage)/AMP.(current)
 Shift: Shift left / Total(Comprehensive)
 Up: Move Up / Power
 Down: Move Down / Energy

Confirm wiring
Power transmission

Display
Models and versions

Permanent Mission of
the screen display

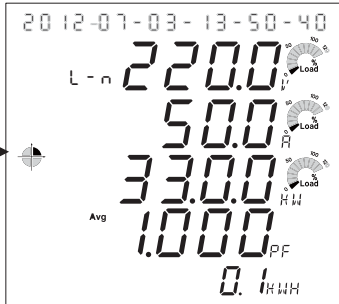

The permanent screen Please refer to the H-1 set Item Description

Press V/A/TH/DM ENTER Key

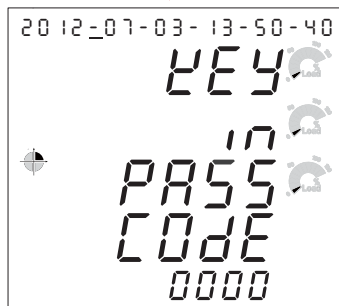

P.COD
Default: 1000

Press V/A/TH/DM ENTER Key

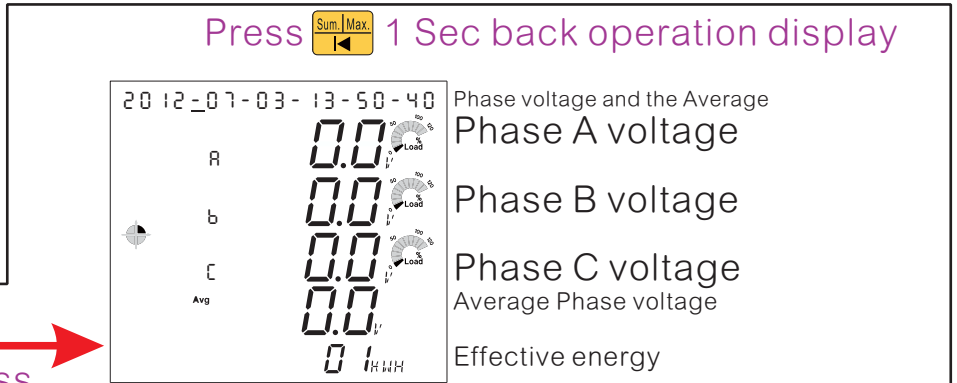
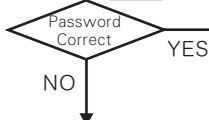

General operating class

Press V/A/TH/DM ENTER Key

Voltage, Current, Total harmonic display group

Press Sum/Max Key

Integrated display group
 (3P3W/3P3W.B/3P3W3 No such function)

Press P/Q/S/PF Key

Power display group

Press Energy Key

Electricity, Time display group

Parameter setting class

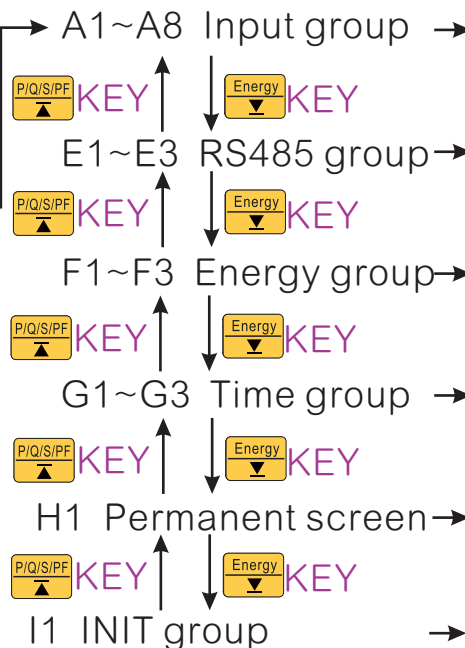

Press **VIA|TH|DM** **ENTER** key (Voltage and Current harmonics screen)

Normal screen **Sum|Max.** 1 seconds, first showed off the voltage value As follows

20 12-07-03- 13-50-40

R 0.00 V Load %

b 0.00 V Load %

c 0.00 V Load %

Avg 0.00 V

0 kWh

Phase voltage and the Average Phase A voltage

Phase B voltage

Phase C voltage

Average Phase voltage

Active energy

Press **VIA|TH|DM** **ENTER** Key ↓

20 12-07-03- 13-50-40

R - b 0.00 V Load %

b - c 0.00 V Load %

c - R 0.00 V Load %

Avg 0.00 V

0 kWh

1.1.1-The Value of the Line voltage and the Average Line voltage

A-B Line Voltage

B-C Line Voltage

C-A Line Voltage

Average line voltage

Active energy

Press **VIA|TH|DM** **ENTER** Key ↓

20 12-07-03- 13-50-40

R 0.00 THDU Load %

b 0.00 THDU Load %

c 0.00 THDU Load %

Avg 0.00 % THDU

0 kWh

1.1.2-Voltage total harmonic distortion

Phase voltage total harmonic THDU/ Phase A THD

THDU/ Phase B THD

THDU/ Phase C THD

Average line voltage THD

Active energy

Press **VIA|TH|DM** **ENTER** Key ↓

20 12-07-03- 13-50-40

R 0.0000 A Load %

b 0.0000 A Load %

c 0.0000 A Load %

Avg 0.0000 A

0 kWh

1.1.3-Phase current values and the average

Phase A current

Phase B current

Phase C current

Average current

Active energy

20 12-07-03- 13-50-40

R 0.0000 A Load %

b 0.0000 A Load %

c 0.0000 A Load %

N 0.0000 A Load %

0 kWh

1.1.4-Phase Current and Neutral Current

Phase A current

Phase B current

Phase C current

Neutral Current

Active energy

Press **VIA|TH|DM** **ENTER** Key ↓

20 12-07-03- 13-50-40

R 0.00 THDI Load %

b 0.00 THDI Load %

c 0.00 THDI Load %

Avg 0.00 % THDI

0 kWh

1.1.5-Current harmonic distortion rate

THDI/Phase A Current THD

THDI/Phase B Current THD

THDI/Phase C Current THD

Average Current THD

Active energy

Press **VIA|TH|DM** **ENTER** Key ↓

To 1.1.1 Display Or Press **Sum|Max.** **ENTER** Key 1 Sec Back to Measurement screen

Press  Shift KEY (Comprehensive screen) Press  Up KEY (Power Parameters)

Normal screen  1 seconds, first showed off the voltage value As follows

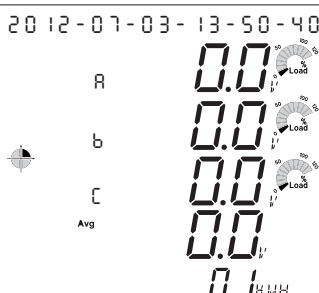

Phase voltage and the Average Phase A voltage
Phase B voltage
Phase C voltage
Average Phase voltage
Active energy

Normal screen  1 seconds, first showed off the voltage value As follows

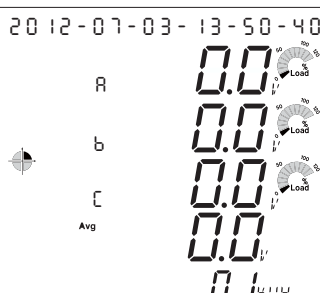

Phase voltage and the Average Phase A voltage
Phase B voltage
Phase C voltage
Average Phase voltage
Active energy

Press  Key ↓

1.2.1-3-phase integrated display-1

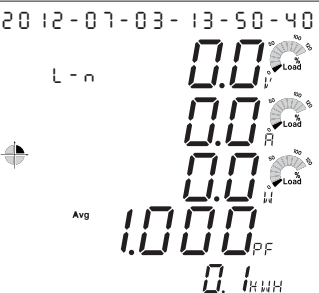

Average Phase voltage
Average current
Total Active power
Average power factor
Active energy

Press  Key ↓

1.3.1-Effective power display

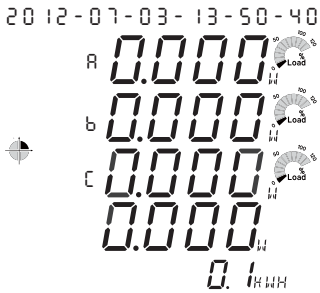

Phase A active power
Phase B active power
Phase C active power
Total Active power
Active energy

Press  Key ↓

1.2.2-3-phase integrated display-2

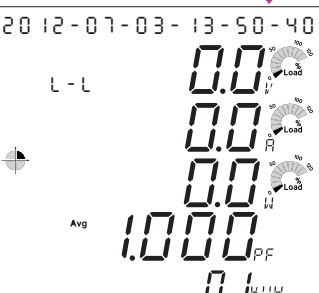

Average Line voltage
Average current
Total Active power
Average power factor
Active energy

Press  Key ↓

1.3.2-Reactive power display

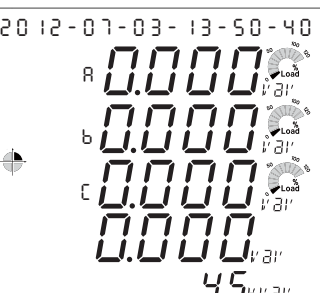

Phase A reactive power
Phase B reactive power
Phase C reactive power
Total reactive power
Reactive electricity

Press  Key ↓

1.2.3-3-phase integrated display-3

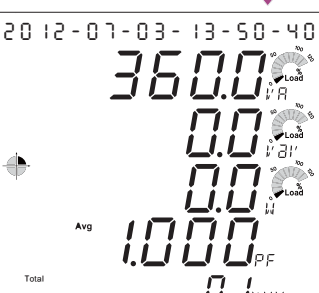

Total Apparent Power
Total Reactive Power
Total Active power
Average power factor
Active energy

Press  Key ↓

1.3.3-Apparent power display

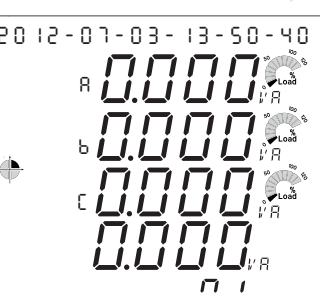

Phase A apparent power
Phase B apparent power
Phase C apparent power
Total Apparent Power
Active energy

Press  Key ↓

1.2.4-3-phase integrated display-4

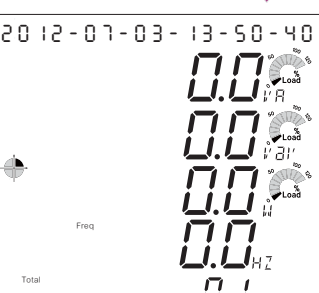

Total Apparent Power
Total Reactive Power
Total Active power
Frequency
Active energy

Press  Key ↓

1.3.4-Power Factor display

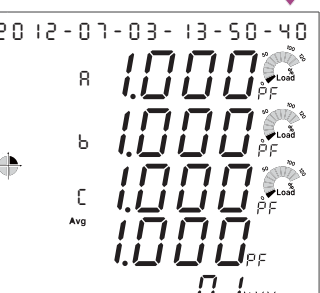

Phase A power factor
Phase B power factor
Phase C power factor
Average Power factor
Active energy

Press  Key ↓ To 1.2.1 Display Or Press  Key 1 Sec Back to Measurement screen

Press  Key ↓

Press  Down KEY (Power parameters)

Press  Key ↓

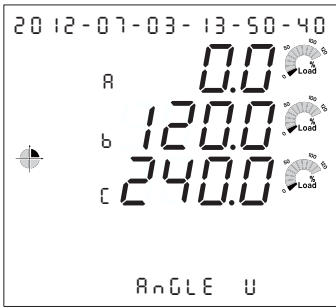

1.3.5-Phase voltage angle
 ©Additional screen display for V3.0 and above version
 VA-VA
 VB-VA
 VC-VA

Press  Key ↓

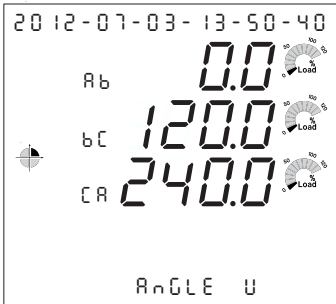

1.3.6-Line voltage angle
 ©Additional screen display for V3.0 and above version
 VAB-VAB
 VBC-VAB
 VCA-VAB

Press  Key ↓

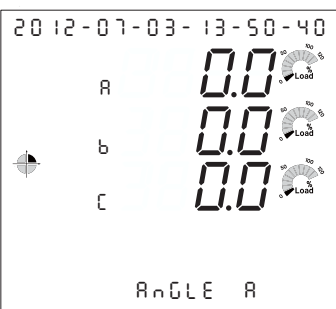

1.3.7-Current phase angle
 ©Additional screen display for V3.0 and above version
 IA-VA (VAB)
 IB-VA (VAB)
 IC-VA (VAB)

Press  Key ↓ To 1.3.1 Display Or
 Press  Key 1 Sec Back to Measurement screen

Normal screen  1 seconds, first showed off the voltage value As follows

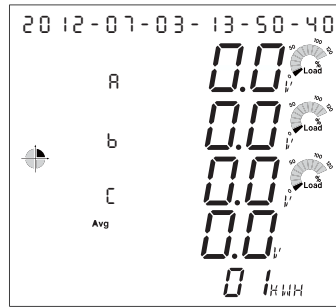

Phase voltage and the Average
 Phase A voltage
 Phase B voltage
 Phase C voltage
 Average Phase voltage
 Active energy

Press  Key ↓

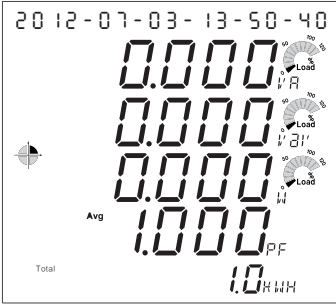

1.4.1-Power display-1
 Total apparent power
 Total reactive power
 Total active power
 Average power factor
 Total Active energy

Press  Key ↓

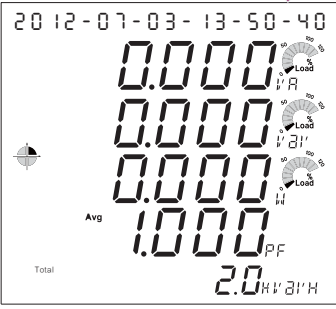

1.4.2-Power display-2
 Total apparent power
 Total reactive power
 Total active power
 Average power factor
 Total reactive electricity

Press  Key ↓

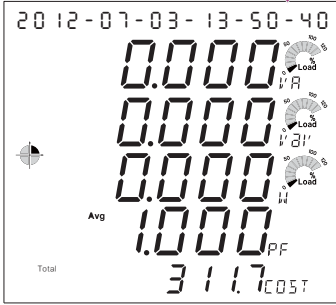

1.4.3-Total electricity bills display
 Total apparent power
 Total reactive power
 Total active power
 Average power factor
 Total electricity bill

Press  Key ↓

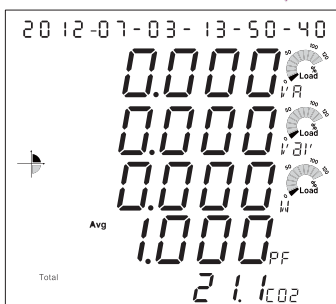

1.4.4-Carbon emissions
 Total apparent power
 Total reactive power
 Total active power
 Average power factor
 Total carbon dioxide(kg)

Press  Key ↓ To 1.4.1 Display Or
 Press  Key 1 Sec Back to Measurement screen

***Engineers set class, non-personnel do not arbitrarily enter the change, in order to avoid abnormal ◦**

INPUT Group

Operation display

↓ Press  Key Enter the setup menus

20 12-07-03-13-50-40

KEY

in

PASS





Code

0000

Password

0000~9999

Default:1000

Press  Key: SET
 Press  Key: SHIFT
 Press  Key: MOVE/INCREASE
 Press  Key: DOWN/DECREASE
 Press  Key: CONFIRM

↓ **Energy** KEY

20 12-07-03-13-50-40

A-1

545

YIRE

3P346

A-1 Voltage Phase line set

Set range is as follows:
 1P2W/1P3W/3P3W/
 3P3W.B (Balanced)/3P3W3/
 3P4W/3P4W.B (Balanced)

Default:3P4W

20 12-07-03-13-50-40

A-2

PT

Pr

600

A-2 Primary-side voltage (PT)

Set range:100~500000V

Default:600

20 12-07-03-13-50-40

A-3

PT

SEC

600

A-3 Secondary-side voltage(PT)

Set range:100~600V

Default:600

20 12-07-03-13-50-40

A-4

CT

Pr

5

A-4 Primary current (CT)

Set range:5~10000A

Default:5

20 12-07-03-13-50-40

A-5

CT

SEC

5

A-5 Secondary current mode selection

Set range:
5A、1A、333mV

Default:5A
(If default is 333mV, it cannot be changed)

20 12-07-03-13-50-40

A-6

YH

VAR-H

0

A-6 Watt-h / Var Clear

ClearPasswords:
0000~9999

Code:2100

20 12-07-03-13-50-40

A-7

noFY

PLod

A-7 P.COD

Set range:
0000~9999

Default:1000

20 12-07-03-13-50-40

A-8

YIRE

CAN

no

A-8 Auto wiring change

©Additional screen display for V3.0 and above version
YES / NO

20 12-07-03-13-50-40

E-1

r485

Addr

1

RS485 Group

E-1 Communication station No.

Set range:001~247

Default:1

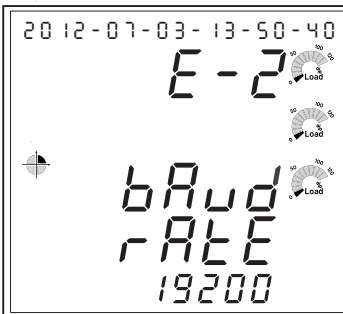

E-2 Communications transmission rate
 Set range:
 1200、2400、4800、
 9600、19200、38400、
 57600、115200
 Default:9600

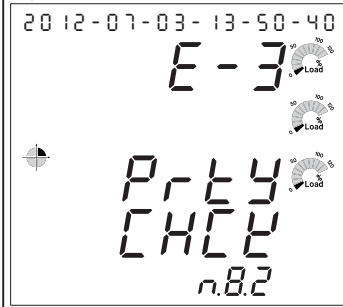
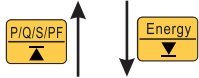

E-3 Parity Check
 Set range:N.8.1、
 N.8.2、O.8.1、E.8.1
 Default:N.8.2

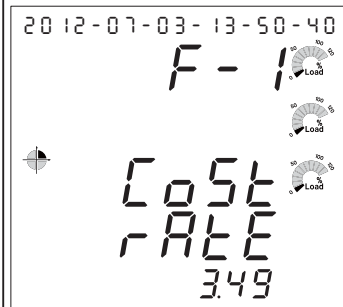

ENEgy Group
F-1 Cost rates
 Set range:
 00.00~99.99
 (per / kWh)
 Default:2.30

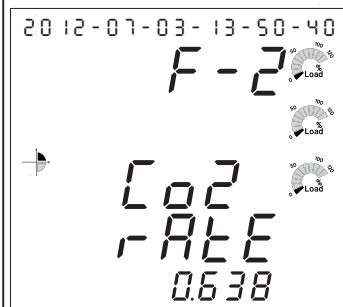

F-2 CO2 ratio
 Set range:
 0.000~9.999(kg/kWh)
 Default:0.638



F-3 Energy unit setting
 ©Additional screen display
 for V3.0 and above version
 Set range:
 0.0001kWh
 0.001kWh
 0.01kWh
 0.1kWh
 1kWh
 0.01MWh
 0.1MWh
 Default:0.1kWh

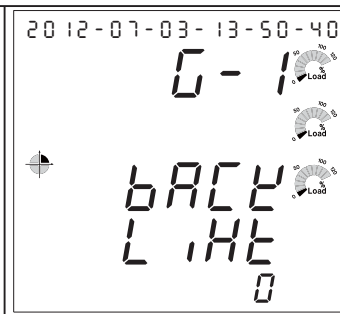

TIME Group
G-1 Backlight time
 Set range:0~15(Minute)
 0 is always lit
 Default:1

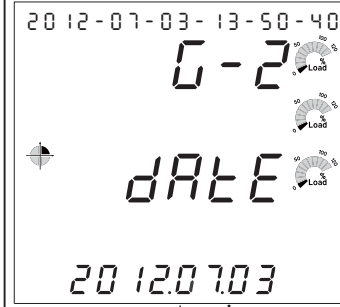

G-2 Date set
 Set range:
 2000.01.01~2099.12.31

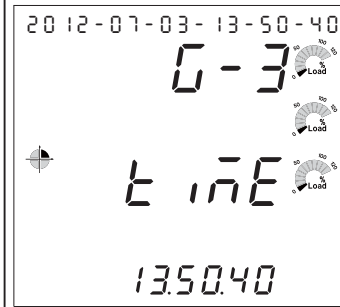

G-3 Time set
 Set range:
 00.00.00~23.59.59

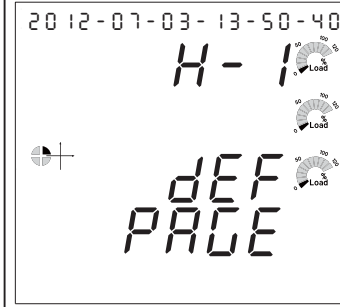

H-1 Permanent screen selection
 Set range:1~4
 Schedule Description
 Default:1

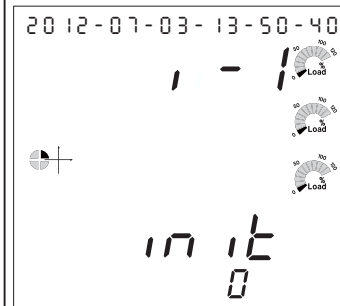

I-1 INIT Restore Default
 Set range:0000~9999
 set:7170
 Default:0

Back To A-1 Display Or
 Press Key1 Sec Back to
 Measurement screen

Auto wiring change

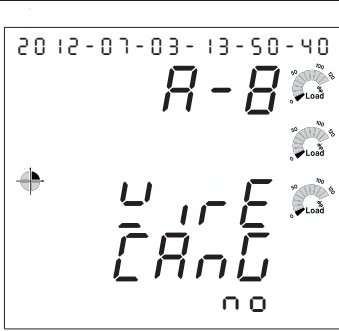

Wire change progress
YES/NO
Ⓞ Additional screen display
for V3.0 and above version

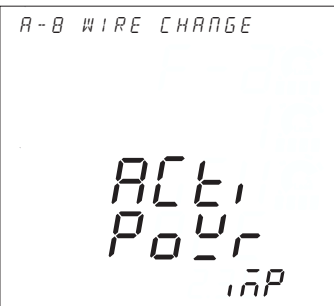

Select system input is
IMP
Ⓞ Additional screen display
for V3.0 and above version

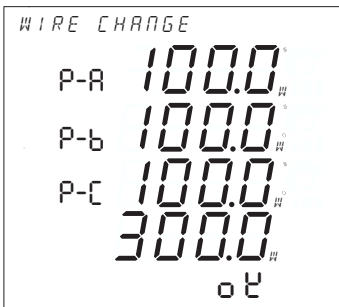

Confirm active power
values:
OK/NO
Ⓞ Additional screen display
for V3.0 and above version

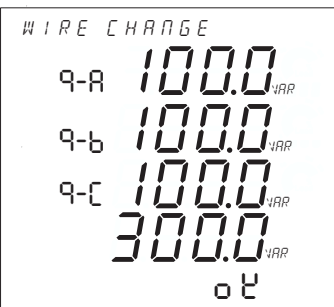

Confirm reactive power
values:
OK/NO
Ⓞ Additional screen display
for V3.0 and above version

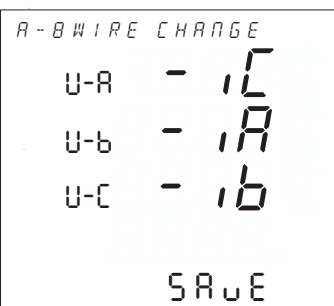

Confirm change complete:
default / save / abort
Ⓞ Additional screen
display for V3.0 and above
version

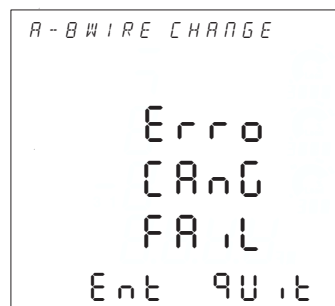

Wiring change failure
enter / quit
Ⓞ Additional screen
display for V3.0 and
above version

Schedule: The Permanent screen instructions

The first

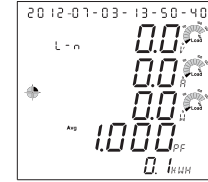

1.2.1-3-phase integrated display-1
Average Phase voltage
Average current
Active power
Average power factor
Active energy

The second

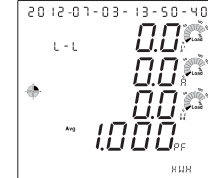

1.2.2-3-phase integrated display-2
Average Line voltage
Average current
Total Active power
Average power factor
Active energy

The third

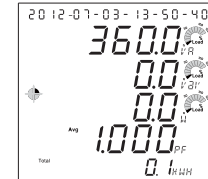

1.2.3-3-phase integrated display-3
Total Apparent Power
Total Reactive Power
Total active power
Average power factor
Active energy

The fourth

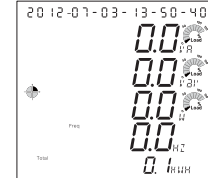

1.2.4-3-phase integrated display-4
Total Apparent Power
Total Reactive Power
Total Active power
Frequency
Active energy

Auto wiring change condition limit :
3P4W-3CT : VN must be correct and $\theta < \pm 59^\circ$
3P4W-1CT : $\theta < \pm 59^\circ$
3P3W-2CT : V2 must be correct and $\theta < \pm 59^\circ$
3P3W-3CT : V2 must be correct and $\theta < \pm 59^\circ$
1P3W : VN must be correct and $\theta < \pm 59^\circ$
1P2W : $\theta < \pm 59^\circ$
3P3W-1CT: N/A

RS485 communication parameters address table (Function code: 03h, 06h, 10h)

General class information (Value automatic recycle after maximum display)

Register Name	Register address	Data Format	Data Length	Measurement range	Unit	R/W	Default	Description
Frequency	0000h	XXXX	2	45.00 ~65.00	Hz /100	R		Frequency (high word)
	0001h	XX.XX						Frequency (low word)
Average phase voltage	0002h	XXXX	2	0~500000.0	V/10	R		Average phase voltage(high word)
	0003h	XXX.X						Average phase voltage(low word)
U l lavg	0004h	XXXX	2	0~500000.0	V/10	R		Average line voltage(high word)
	0005h	XXX.X						Average line voltage(low word)
I avg	0006h	XXXX	2	0~10000.000	A/1000	R		Average current(high word)
	0007h	X.XXX						Average current(low word)
In	0008h	XXXX	2	0~10000.000	A/1000	R		Neutral current(high word)
	0009h	X.XXX						Neutral current(low word)
Psum	000Ah	XXXX	2	-199999999 ~999999999	W	R		Total active power(high word)
	000Bh	XXXX						Total active power(low word)
Qsum	000Ch	XXXX	2	-199999999 ~999999999	VAR	R		Total reactive power(high word)
	000Dh	XXXX						Total reactive power(low word)
Ssum	000Eh	XXXX	2	-199999999 ~999999999	VA	R		Total apparent power(high word)
	000Fh	XXXX						Total apparent power(low word)
PF avg	0010h	XXXX	2	-1.000 ~1.000	PF /1000	R		Average power factor(high word)
	0011h	X.XXX						Average power factor(low word)
Ea	0012h	XXXX	2	0~99999999.9	kWh /10	R/W		Active energy(high word)
	0013h	XXX.X						Active energy(low word)
Er	0014h	XXXX	2	0~99999999.9	kVARh /10	R/W		Reactive energy(high word)
	0015h	XXX.X						Reactive energy(low word)
Cost	0016h	XXXX	2	0~99999999.9	\$/10	R		Total electricity bill(high word)
	0017h	XXX.X						Total electricity bill(low word)
CO2	0018h	XXXX	2	0~99999999.9	kg/10	R		The total carbon dioxide(high word)
	0019h	XXX.X						The total carbon dioxide(low word)
UA	001Ah	XXXX	2	0~500000.0	V/10	R		Phase A voltage(high word)
	001Bh	XXX.X						Phase A voltage(low word)
UB	001Ch	XXXX	2	0~500000.0	V/10	R		Phase B voltage(high word)
	001Dh	XXX.X						Phase B voltage(low word)
UC	001Eh	XXXX	2	0~500000.0	V/10	R		Phase C voltage(high word)
	001Fh	XXX.X						Phase C voltage(low word)
UAB	0020h	XXXX	2	0~500000.0	V/10	R		AB line voltage(high word)
	0021h	XXX.X						AB line voltage(low word)
UBC	0022h	XXXX	2	0~500000.0	V/10	R		BC line voltage(high word)
	0023h	XXX.X						BC line voltage(low word)
UCA	0024h	XXXX	2	0~500000.0	V/10	R		CA line voltage(high word)
	0025h	XXX.X						CA line voltage(low word)
IA	0026h	XXXX	2	0~10000.000	A/1000	R		Phase A current(high word)
	0027h	X.XXX						Phase A current(low word)
IB	0028h	XXXX	2	0~10000.000	A/1000	R		Phase B current(high word)
	0029h	X.XXX						Phase B current(low word)
IC	002Ah	XXXX	2	0~10000.000	A/1000	R		Phase C current(high word)
	002Bh	X.XXX						Phase C current(low word)
PA	002Ch	XXXX	2	-199999999 ~999999999	W	R		Phase A active power(high word)
	002Dh	XXXX						Phase A active power(low word)
PB	002Eh	XXXX	2	-199999999 ~999999999	W	R		Phase B active power(high word)
	002Fh	XXXX						Phase B active power(low word)
PC	0030h	XXXX	2	-199999999 ~999999999	W	R		Phase C active power(high word)
	0031h	XXXX						Phase C active power(low word)
QA	0032h	XXXX	2	-199999999 ~999999999	VAR	R		Phase A reactive power(high word)
	0033h	XXXX						Phase A reactive power(low word)
QB	0034h	XXXX	2	-199999999 ~999999999	VAR	R		Phase B reactive power(high word)
	0035h	XXXX						Phase B reactive power(low word)
QC	0036h	XXXX	2	-199999999 ~999999999	VAR	R		Phase C reactive power(high word)
	0037h	XXXX						Phase C reactive power(low word)
SA	0038h	XXXX	2	-199999999 ~999999999	VA	R		Phase A apparent power(high word)
	0039h	XXXX						Phase A apparent power(low word)
SB	003Ah	XXXX	2	-199999999 ~999999999	VA	R		Phase B apparent power(high word)
	003Bh	XXXX						Phase B apparent power(low word)
SC	003Ch	XXXX	2	-199999999 ~999999999	VA	R		Phase C apparent power(high word)
	003Dh	XXXX						Phase C apparent power(low word)
PFA	003Eh	XXXX	2	-1.000 ~1.000	PF/ 1000	R		Phase A Power Factor(high word)
	003Fh	X.XXX						Phase A Power Factor(low word)
PFB	0040h	XXXX	2	-1.000 ~1.000	PF/ 1000	R		Phase B Power Factor(high word)
	0041h	X.XXX						Phase B Power Factor(low word)
PFC	0042h	XXXX	2	-1.000 ~1.000	PF/ 1000	R		Phase C Power Factor(high word)
	0043h	X.XXX						Phase C Power Factor(low word)
LT	0044h	XX	1	82=R, 76=L, 67=C		R		R:Resistive, L:Inductive, C:Capacitive

Additional 8+1 digits for V3.0 and above version

General class information

Register Name	Register address	Data Format	Data Length	Measurement range	Unit	R / W	Default	Description
THDUA	0045h	XXX.X	1	0~100.0	%/10	R		Phase A voltage total harmonic(3P3W,THDUAB)
THDUB	0046h	XXX.X	1	0~100.0	%/10	R		Phase B voltage total harmonic(3P3W,THDUBC)
THDUC	0047h	XXX.X	1	0~100.0	%/10	R		Phase C voltage total harmonic(3P3W,THDUCA)
THDUavg	0048h	XXX.X	1	0~100.0	%/10	R		Average voltage total harmonic
THDIA	0049h	XXX.X	1	0~100.0	%/10	R		Phase A current total harmonic
THDIB	004Ah	XXX.X	1	0~100.0	%/10	R		Phase B current total harmonic
THDIC	004Bh	XXX.X	1	0~100.0	%/10	R		Phase C current total harmonic
THDIavg	004Ch	XXX.X	1	0~100.0	%/10	R		Average total harmonic current

Input group setting class

Register Name	Register address	Data Format	Data Length	Measurement range	Unit	R / W	Default	Description
Voltage wiring Wire-U	004Dh	X	1	0~6		R/W	5	0:1P2W 1:1P3W 2:3P3W 3:3P3W.B 4:3P3W.3 5:3P4W 6:3P4W.B
PT-Pri	004Eh	XXXX	2	100~500000	V	R/W	600	PT Primary side voltage setting(high word)
	004Fh	XXXX						PT Primary side voltage setting(low word)
PT-Sec	0050h	XXXX	1	100~600	V	R/W	600	PT Secondary voltage settings
CT-Pri	0051h	XXXXX	1	1~10000	A	R/W	5	CT Primary current setting
P.code	0052h	XXXX	1	0000~9999		R/W	1000	Clearance password change
CT-Sec	0083h	X	1	0~2		R/W	0	CT Secondary current setting 0:5A 1:1A 2:333mV

*CT secondary current (0083h), if 333mV is specified, this address cannot be written, can only be read, and the response value is fixed at 2.

RS485 communication group settings class

Register Name	Register address	Data Format	Data Length	Measurement range	Unit	R / W	Default	Description
Addr	0053h	XXX	1	1~247		R/W	1	The Communication Station No. setting
Baud	0054h	X	1	0~7		R/W	3	0:1200 , 1:2400 , 2:4800 , 3:9600 , 4:19200 , 5:38400 6:57600, 7:115200
Parity	0055h	X	1	0~3		R/W	1	0:N81 , 1:N82 , 2:O81 , 3:E81

Cost group setting class

Register Name	Register address	Data Format	Data Length	Measurement range	Unit	R / W	Default	Description
Cost	0056h	XX.XX	1	00.00~99.99		R/W	2.30	kWh the cost ratio setting
CO ₂	0057h	X.XXX	1	0.000~9.999		R/W	0.638	kWh of CO ₂ ratio setting

Time group settings class

Register Name	Register address	Data Format	Data Length	Measurement range	Unit	R / W	Default	Description
Back-Light	0058h	XX	1	0~15		R/W	1	0~15Minute, 0 is Steadily lit
Year	0059h	XX	1	0~99		R/W		0~99 = 2000~2099
Month	005Ah	XX	1	1~12		R/W		
Day	005Bh	XX	1	1~31		R/W		
Time	005Ch	XX	1	0~23		R/W		
Minute	005Dh	XX	1	0~59		R/W		
Second	005Eh	XX	1	0~59		R/W		

Permanent screen group settings class

Register Name	Register address	Data Format	Data Length	Measurement range	Unit	R / W	Default	Description
Def. Page	005Fh	X	1	1~4		R/W	1	1: V-N / A / P / PF / kWh 2: V-L / A / P / PF / kWh 3: S / Q / P / PF / kWh 4: S / Q / P / F / kWh

Register Name	Register address	Data Format	Data Length	Measurement range	Unit	R / W	Default	Information
INIT	0060h	XXXX	1	0000~9999		R/W	0	Set:7170,Restore Default

Energy group data (Additional data for V3.0 and above version)

Register Name	Register address	Data Format	Data Length	Measurement range	Unit	R / W	Default	Description
Energy Unit	0090h	X	1	0~6		R/W	3	0: 0.0001kWh 1: 0.001kWh 2: 0.01kWh 3: 0.1kWh 4: 1kWh 5: 0.01MWh 6: 0.1MWh
AE-IMP	0091h	XXXX	2	0.0 ~ 99999999.9 kWh	kWh/10	R		Import active energy(High Word)
	0092h	XXX.X						Import active energy(Low Word)
AE-EXP	0093h	XXXX	2	0.0 ~ 99999999.9 kWh	kWh/10	R		Export active energy(High Word)
	0094h	XXX.X						Export active energy(Low Word)
AE-Net	0095h	XXXX	2	-9999999.9 ~ 99999999.9 kWh	kWh/10	R		Net active energy(High Word)
	0096h	XXX.X						Net active energy(Low Word)
RE-IMP	0097h	XXXX	2	0.0 ~ 99999999.9 kVARh	kVARh/10	R		Import reactive energy(High Word)
	0098h	XXX.X						Import reactive energy(Low Word)
RE-EXP	0099h	XXXX	2	0.0 ~ 99999999.9 kVARh	kVARh/10	R		Export reactive energy(High Word)
	009Ah	XXX.X						Export reactive energy(Low Word)
RE-Net	009Bh	XXXX	2	-9999999.9 ~ 99999999.9 kVARh	kVARh/10	R		Net reactive energy(High Word)
	009Ch	XXX.X						Net reactive energy(Low Word)
SE-TOTAL	009Dh	XXXX	2	0.0 ~ 99999999.9 kVAh	kVAh/10	R		Total apparent energy(High Word)
	009Eh	XXX.X						Total apparent energy(Low Word)
Reset	009Fh	X	1	0~4		R/W	0	0: None 1: All(Ea / Er / SE-TOTAL / CO ₂ / COST) 2: Energy(Ea / Er / SE-Total) 3: CO ₂ 4: COST

Event logging setting (Code:03h,06h,10h)(Additional data for V3.0 and above version)

Register Name	Address	Measurement range	Description	Default	R/W
Event Log	0300h	0~1	Event logging function enable 0:OFF 1:ON	0	R/W
Event Log ch	0301h	0~65535	Logging enable of each channel Bit0:1st event logging~Bit15:16th event logging 0:OFF 1:ON	0	R/W
Event Log ch 1 Parameter SLCT	0302h	0~32	Parameter: 0:FREQ 1:UA 2:UB 3:UC 4:ULNavg 5:UAB 6:UBC 7:UCA 8:ULLavg 9:IA 10:IB 11:IC 12:lavg 13:PA 14:PB 15:PC 16:PSUM 17:QA 18:QB 19:QC 20:QSUM 21:SA 22:SB 23:SC 24:SSUM 25:PFA 26:PFB 27:PFC 28:PFAVG 29:D.PSUM 30:D.QSUM 31:D.SSUM 32:D.I.AVG	12	R/W
Event Log ch 1 Compare	0303h	0~2	Compare condition 0:more than(>) 1:equal(=) 2:less than(<)	0	R/W
Event Log ch 1 SP	0304h	According to parameter range	Set point (High Word)	1000	R/W
	0305h		Set point (Low Word)		
Event Log ch 1 delay time	0306h	0~3000	Delay time(x10mS)	0	R/W
Event Log ch 2 Parameter SLCT	0307h	0~32	Refer to ch1	12	R/W
Event Log ch 2 Compare	0308h	0~2	Compare condition 0:more than(>) 1:equal(=) 2:less than(<)	0	R/W
Event Log ch 2 SP	0309h	According to parameter range	Set point (High Word)	1000	R/W
	030Ah		Set point (Low Word)		
Event Log ch 2 delay time	030Bh	0~3000	Delay time(x10mS)	0	R/W
Event Log ch 3 Parameter SLCT	030Ch	0~32	Refer to ch1	12	R/W
Event Log ch 3 Compare	030Dh	0~2	Compare condition 0:more than(>) 1:equal(=) 2:less than(<)	0	R/W
Event Log ch 3 SP	030Eh	According to parameter range	Set point (High Word)	1000	R/W
	030Fh		Set point (Low Word)		
Event Log ch 3 delay time	0310h	0~3000	Delay time(x10mS)	0	R/W
Event Log ch 4 Parameter SLCT	0311h	0~32	Refer to ch1	12	R/W
Event Log ch 4 Compare	0312h	0~2	Compare condition 0:more than(>) 1:equal(=) 2:less than(<)	0	R/W
Event Log ch 4 SP	0313h	According to parameter range	Set point (High Word)	1000	R/W
	0314h		Set point (Low Word)		
Event Log ch 4 delay time	0315h	0~3000	Delay time(x10mS)	0	R/W

Register Name	Address	Measurement range	Description	Default	R/W
Event Log ch 5 Parameter SLCT	0316h	0~32	Refer to ch1	12	R/W
Event Log ch 5 Compare	0317h	0~2	Compare condition 0:more than(>) 1:equal(=) 2:less than(<)	0	R/W
Event Log ch 5 SP	0318h	According to parameter range	Set point (High Word)	1000	R/W
	0319h		Set point (Low Word)		
Event Log ch 5 delay time	031Ah	0~3000	Delay time(x10mS)	0	R/W
Event Log ch 6 Parameter SLCT	031Bh	0~32	Refer to ch1	12	R/W
Event Log ch 6 Compare	031Ch	0~2	Compare condition 0:more than(>) 1:equal(=) 2:less than(<)	0	R/W
Event Log ch 6 SP	031Dh	According to parameter range	Set point (High Word)	1000	R/W
	031Eh		Set point (Low Word)		
Event Log ch 6 delay time	031Fh	0~3000	Delay time(x10mS)	0	R/W
Event Log ch 7 Parameter SLCT	0320h	0~32	Refer to ch1	12	R/W
Event Log ch 7 Compare	0321h	0~2	Compare condition 0:more than(>) 1:equal(=) 2:less than(<)	0	R/W
Event Log ch 7 SP	0322h	According to parameter range	Set point (High Word)	1000	R/W
	0323h		Set point (Low Word)		
Event Log ch 7 delay time	0324h	0~3000	Delay time(x10mS)	0	R/W
Event Log ch 8 Parameter SLCT	0325h	0~32	Refer to ch1	12	R/W
Event Log ch 8 Compare	0326h	0~2	Compare condition 0:more than(>) 1:equal(=) 2:less than(<)	0	R/W
Event Log ch 8 SP	0327h	According to parameter range	Set point (High Word)	1000	R/W
	0028h		Set point (Low Word)		
Event Log ch 8 delay time	0029h	0~3000	Delay time(x10mS)	0	R/W
Event Log ch 9 Parameter SLCT	032Ah	0~32	Refer to ch1	12	R/W
Event Log ch 9 Compare	032Bh	0~2	Compare condition 0:more than(>) 1:equal(=) 2:less than(<)	0	R/W
Event Log ch 9 SP	032Ch	According to parameter range	Set point (High Word)	1000	R/W
	032Dh		Set point (Low Word)		
Event Log ch 9 delay time	032Eh	0~3000	Delay time(x10mS)	0	R/W
Event Log ch 10 Parameter SLCT	032Fh	0~32	Refer to ch1	12	R/W
Event Log ch 10 Compare	0330h	0~2	Compare condition 0:more than(>) 1:equal(=) 2:less than(<)	0	R/W
Event Log ch 10 SP	0331h	According to parameter range	Set point (High Word)	1000	R/W
	0332h		Set point (Low Word)		
Event Log ch 10 delay time	0333h	0~3000	Delay time(x10mS)	0	R/W
Event Log ch 11 Parameter SLCT	0334h	0~32	Refer to ch1	12	R/W
Event Log ch 11 Compare	0335h	0~2	Compare condition 0:more than(>) 1:equal(=) 2:less than(<)	0	R/W

Register Name	Address	Measurement range	Description	Default	R/W
Event Log ch 11 SP	0336h	According to parameter range	Set point (High Word)	1000	R/W
	0337h		Set point (Low Word)		
Event Log ch 11 delay time	0338h	0~3000	Delay time(x10mS)	0	R/W
Event Log ch 12 Parameter SLCT	0339h	0~32	Refer to ch1	12	R/W
Event Log ch 12 Compare	033Ah	0~2	Compare condition 0:more than(>) 1:equal(=) 2:less than(<)	0	R/W
Event Log ch 12 SP	033Bh	According to parameter range	Set point (High Word)	1000	R/W
	033Ch		Set point (Low Word)		
Event Log ch 12 delay time	033Dh	0~3000	Delay time(x10mS)	0	R/W
Event Log ch 13 Parameter SLCT	033Eh	0~32	Refer to ch1	12	R/W
Event Log ch 13 Compare	033Fh	0~2	Compare condition 0:more than(>) 1:equal(=) 2:less than(<)	0	R/W
Event Log ch 13 SP	0340h	According to parameter range	Set point (High Word)	1000	R/W
	0341h		Set point (Low Word)		
Event Log ch 13 delay time	0342h	0~3000	Delay time(x10mS)	0	R/W
Event Log ch 14 Parameter SLCT	0343h	0~32	Refer to ch1	12	R/W
Event Log ch 14 Compare	0344h	0~2	Compare condition 0:more than(>) 1:equal(=) 2:less than(<)	0	R/W
Event Log ch 14 SP	0345h	According to parameter range	Set point (High Word)	1000	R/W
	0346h		Set point (Low Word)		
Event Log ch 14 delay time	0347h	0~3000	Delay time(x10mS)	0	R/W
Event Log ch 15 Parameter SLCT	0348h	0~32	Refer to ch1	12	R/W
Event Log ch 15 Compare	0349h	0~2	Compare condition 0:more than(>) 1:equal(=) 2:less than(<)	0	R/W
Event Log ch 15 SP	034Ah	According to parameter range	Set point (High Word)	1000	R/W
	034Bh		Set point (Low Word)		
Event Log ch 15 delay time	034Ch	0~3000	Delay time(x10mS)	0	R/W
Event Log ch 16 Parameter SLCT	034Dh	0~32	Refer to ch1	12	R/W
Event Log ch 16 Compare	034Eh	0~2	Compare condition 0:more than(>) 1:equal(=) 2:less than(<)	0	R/W
Event Log ch 16 SP	034Fh	According to parameter range	Set point (High Word)	1000	R/W
	0350h		Set point (Low Word)		
Event Log ch 16 delay time	0351h	0~3000	Delay time(x10mS)	0	R/W
Event Log Clear	0352h	0 or 55h	Clear all event logs (0:None 55h:Reset)	0	R/W

Event logging data reading (Code:03h):(Additional data for V3.0 and above version)

Register Name	Address	Measurement range	Description	Default	R/W
Event Log last NO.	0600h	0~16	Last logging NO. 0: None 1~16:New number		R
Event Log 1					
Event Source 1	0601h	1~16	Event trigger source 1~16:Event Setting NO. 1~16		R
Event Status 1	0602h	0~1	Event status 0:Recover 1:Alert		R
Event Log 1 Parameter	0603h	0~32	Alarm item 0:FREQ 1:UA 2:UB 3:UC 4:ULNavg 5:UAB 6:UBC 7:UCA 8:ULLavg 9:IA 10:IB 11:IC 12:Iavg 13:PA 14:PB 15:PC 16:PSUM 17:QA 18:QB 19:QC 20:QSUM 21:SA 22:SB 23:SC 24:SSUM 25:PFA 26:PFB 27:PFC 28:PFAVG 29:D.PSUM 30:D.QSUM 31:D.SSUM 32:D.I.AVG		R
Event Log 1 Value	0604h	According to item range	Alarm value(High Word)		R
	0605h		Alarm value(Low Word)		
Year	0606h	2000~2099	Year		R
Month	0607h	1~12	Month		R
Day	0608h	1~31	Day		R
Hour	0609h	0~23	Hour		R
Minute	060Ah	0~59	Minute		R
Second	060Bh	0~59	Second		R
Event Log 2					
Event Source 2	060Ch	1~16	Event trigger source 1~16:Event Setting NO. 1~16		R
Event Status 2	060Dh	0~1	Event status 0:Recover 1:Alert		R
Event Log 2 Parameter	060Eh	0~32	Refer to Log1		R
Event Log 2 Value	060Fh	According to item range	Alarm value(High Word)		R
	0610h		Alarm value(Low Word)		
Year	0611h	2000~2099	Year		R
Month	0612h	1~12	Month		R
Day	0613h	1~31	Day		R
Hour	0614h	0~23	Hour		R
Minute	0615h	0~59	Minute		R
Second	0616h	0~59	Second		R
Event Log 3					
Event Source 3	0617h	1~16	Event trigger source 1~16:Event Setting NO. 1~16		R
Event Status 3	0618h	0~1	Event status 0:Recover 1:Alert		R
Event Log 3 Parameter	0619h	0~32	Refer to Log1		R
Event Log 3 Value	061Ah	According to item range	Alarm value(High Word)		R
	061Bh		Alarm value(Low Word)		
Year	061Ch	2000~2099	Year		R
Month	061Dh	1~12	Month		R
Day	061Eh	1~31	Day		R
Hour	061Fh	0~23	Hour		R
Minute	0620h	0~59	Minute		R
Second	0621h	0~59	Second		R

Register Name	Address	Measurement range	Description	Default	R/W
Event Log 4					
Event Source 4	0622h	1~16	Event trigger source 1~16:Event Setting NO. 1~16		R
Event Status 4	0623h	0~1	Event status 0:Recover 1:Alert		R
Event Log 4 Parameter	0624h	0~32	Refer to Log1		R
Event Log 4 Value	0625h	According to item range	Alarm value(High Word)		R
	0626h		Alarm value(Low Word)		
Year	0627h	2000~2099	Year		R
Month	0628h	1~12	Month		R
Day	0629h	1~31	Day		R
Hour	062Ah	0~23	Hour		R
Minute	062Bh	0~59	Minute		R
Second	062Ch	0~59	Second		R
Event Log 5					
Event Source 5	062Dh	1~16	Event trigger source 1~16:Event Setting NO. 1~16		R
Event Status 5	062Eh	0~1	Event status 0:Recover 1:Alert		R
Event Log 5 Parameter	062Fh	0~32	Refer to Log1		R
Event Log 5 Value	0630h	According to item range	Alarm value(High Word)		R
	0631h		Alarm value(Low Word)		
Year	0632h	2000~2099	Year		R
Month	0633h	1~12	Month		R
Day	0634h	1~31	Day		R
Hour	0635h	0~23	Hour		R
Minute	0636h	0~59	Minute		R
Second	0637h	0~59	Second		R
Event Log 6					
Event Source 6	0638h	1~16	Event trigger source 1~16:Event Setting NO. 1~16		R
Event Status 6	0639h	0~1	Event status 0:Recover 1:Alert		R
Event Log 6 Parameter	063Ah	0~32	Refer to Log1		R
Event Log 6 Value	063Bh	According to item range	Alarm value(High Word)		R
	063Ch		Alarm value(Low Word)		
Year	063Dh	2000~2099	Year		R
Month	063Eh	1~12	Month		R
Day	063Fh	1~31	Day		R
Hour	0640h	0~23	Hour		R
Minute	0641h	0~59	Minute		R
Second	0642h	0~59	Second		R
Event Log 7					
Event Source 7	0643h	1~16	Event trigger source 1~16:Event Setting NO. 1~16		R
Event Status 7	0644h	0~1	Event status 0:Recover 1:Alert		R
Event Log 7 Parameter	0645h	0~32	Refer to Log1		R
Event Log 7 Value	0646h	According to item range	Alarm value(High Word)		R
	0647h		Alarm value(Low Word)		
Year	0648h	2000~2099	Year		R
Month	0649h	1~12	Month		R
Day	064Ah	1~31	Day		R
Hour	064Bh	0~23	Hour		R
Minute	064Ch	0~59	Minute		R
Second	064Dh	0~59	Second		R

Register Name	Address	Measurement range	Description	Default	R/W
Event Log 8					
Event Source 8	064Eh	1~16	Event trigger source 1~16:Event Setting NO. 1~16		R
Event Status 8	064Fh	0~1	Event status 0:Recover 1:Alert		R
Event Log 8 Parameter	0650h	0~32	Refer to Log1		R
Event Log 8 Value	0651h	According to item range	Alarm value(High Word)		R
	0652h		Alarm value(Low Word)		
Year	0653h	2000~2099	Year		R
Month	0654h	1~12	Month		R
Day	0655h	1~31	Day		R
Hour	0656h	0~23	Hour		R
Minute	0657h	0~59	Minute		R
Second	0658h	0~59	Second		R
Event Log 9					
Event Source 9	0659h	1~16	Event trigger source 1~16:Event Setting NO. 1~16		R
Event Status 9	065Ah	0~1	Event status 0:Recover 1:Alert		R
Event Log 9 Parameter	065Bh	0~32	Refer to Log1		R
Event Log 9 Value	065Ch	According to item range	Alarm value(High Word)		R
	065Dh		Alarm value(Low Word)		
Year	065Eh	2000~2099	Year		R
Month	065Fh	1~12	Month		R
Day	0660h	1~31	Day		R
Hour	0661h	0~23	Hour		R
Minute	0662h	0~59	Minute		R
Second	0663h	0~59	Second		R
Event Log 10					
Event Source 10	0664h	1~16	Event trigger source 1~16:Event Setting NO. 1~16		R
Event Status 10	0665h	0~1	Event status 0:Recover 1:Alert		R
Event Log 10 Parameter	0666h	0~32	Refer to Log1		R
Event Log 10 Value	0667h	According to item range	Alarm value(High Word)		R
	0668h		Alarm value(Low Word)		
Year	0669h	2000~2099	Year		R
Month	066Ah	1~12	Month		R
Day	066Bh	1~31	Day		R
Hour	066Ch	0~23	Hour		R
Minute	066Dh	0~59	Minute		R
Second	066Eh	0~59	Second		R
Event Log 11					
Event Source 11	066Fh	1~16	Event trigger source 1~16:Event Setting NO. 1~16		R
Event Status 11	0670h	0~1	Event status 0:Recover 1:Alert		R
Event Log 11 Parameter	0671h	0~32	Refer to Log1		R
Event Log 11 Value	0672h	According to item range	Alarm value(High Word)		R
	0673h		Alarm value(Low Word)		
Year	0674h	2000~2099	Year		R
Month	0675h	1~12	Month		R
Day	0676h	1~31	Day		R
Hour	0677h	0~23	Hour		R
Minute	0678h	0~59	Minute		R
Second	0679h	0~59	Second		R

Register Name	Address	Measurement range	Description	Default	R/W
Event Log 12					
Event Source 12	067Ah	1~16	Event trigger source 1~16:Event Setting NO. 1~16		R
Event Status 12	067Bh	0~1	Event status 0:Recover 1:Alert		R
Event Log 12 Parameter	067Ch	0~32	Refer to Log1		R
Event Log 12 Value	067Dh	According to item range	Alarm value(High Word)		R
	067Eh		Alarm value(Low Word)		
Year	067Fh	2000~2099	Year		R
Month	0680h	1~12	Month		R
Day	0681h	1~31	Day		R
Hour	0682h	0~23	Hour		R
Minute	0683h	0~59	Minute		R
Second	0684h	0~59	Second		R
Event Log 13					
Event Source 13	0685h	1~16	Event trigger source 1~16:Event Setting NO. 1~16		R
Event Status 13	0686h	0~1	Event status 0:Recover 1:Alert		R
Event Log 13 Parameter	0687h	0~32	Refer to Log1		R
Event Log 13 Value	0688h	According to item range	Alarm value(High Word)		R
	0689h		Alarm value(Low Word)		
Year	068Ah	2000~2099	Year		R
Month	068Bh	1~12	Month		R
Day	068Ch	1~31	Day		R
Hour	068Dh	0~23	Hour		R
Minute	068Eh	0~59	Minute		R
Second	068Fh	0~59	Second		R
Event Log 14					
Event Source 14	0690h	1~16	Event trigger source 1~16:Event Setting NO. 1~16		R
Event Status 14	0691h	0~1	Event status 0:Recover 1:Alert		R
Event Log 14 Parameter	0692h	0~32	Refer to Log1		R
Event Log 14 Value	0693h	According to item range	Alarm value(High Word)		R
	0694h		Alarm value(Low Word)		
Year	0695h	2000~2099	Year		R
Month	0696h	1~12	Month		R
Day	0697h	1~31	Day		R
Hour	0698h	0~23	Hour		R
Minute	0699h	0~59	Minute		R
Second	069Ah	0~59	Second		R
Event Log 15					
Event Source 15	069Bh	1~16	Event trigger source 1~16:Event Setting NO. 1~16		R
Event Status 15	069Ch	0~1	Event status 0:Recover 1:Alert		R
Event Log 15 Parameter	069Dh	0~32	Refer to Log1		R
Event Log 15 Value	069Eh	According to item range	Alarm value(High Word)		R
	069Fh		Alarm value(Low Word)		
Year	06A0h	2000~2099	Year		R
Month	06A1h	1~12	Month		R
Day	06A2h	1~31	Day		R
Hour	06A3h	0~23	Hour		R
Minute	06A4h	0~59	Minute		R
Second	06A5h	0~59	Second		R

Register Name	Address	Measurement range	Description	Default	R/W
Event Log 16					
Event Source 16	06A6h	1~16	Event trigger source 1~16: Event Setting NO. 1~16		R
Event Status 16	06A7h	0~1	Event status 0:Recover 1:Alert		R
Event Log 16 Parameter	06A8h	0~32	Refer to Log1		R
Event Log 16 Value	06A9h	According to item range	Alarm value(High Word)		R
	06AAh		Alarm value(Low Word)		
Year	06ABh	2000~2099	Year		R
Month	06ACh	1~12	Month		R
Day	06ADh	1~31	Day		R
Hour	06AEh	0~23	Hour		R
Minute	06AFh	0~59	Minute		R
Second	06B0h	0~59	Second		R

Phase angle data reading (Additional data for V3.0 and above version)

Register Name	Address	Measurement range	Description	Default	R/W
Phasor Diagram VB lag VA	0700h	0~3600	Phasor Diagram VB lag VA		R
Phasor Diagram VC lag VA	0701h	0~3600	Phasor Diagram VC lag VA		R
Phasor Diagram IA lag VA	0702h	0~3600	Phasor Diagram IA lag VA		R
Phasor Diagram IB lag VA	0703h	0~3600	Phasor Diagram IB lag VA		R
Phasor Diagram IC lag VA	0704h	0~3600	Phasor Diagram IC lag VA		R
Phasor Diagram VBC lag VAB	0705h	0~3600	Phasor Diagram VBC lag VAB		R
Phasor Diagram VCA lag VAB	0706h	0~3600	Phasor Diagram VCA lag VAB		R
Phasor Diagram IA lag VAB	0707h	0~3600	Phasor Diagram IA lag VAB		R
Phasor Diagram IB lag VAB	0708h	0~3600	Phasor Diagram IB lag VAB		R
Phasor Diagram IC lag VAB	0709h	0~3600	Phasor Diagram IC lag VAB		R

Client Custom class

Register Name	Register address	Data Format	Data Length	Measurement/Set Range	Unit	R/W	Default	Description
Client Custom 1	5000h	XX	1	0~76(0x4c)		R/W	0x0000h	This regional data to set the following 20 addresses (5014h~5027h) content of the information, That is redefining 5014h~5027h address information significance Address correspondence to: 5000h set 5014h corresponding address data content. Address correspondence to: 5001h set 5015h corresponding address data content. Address correspondence to: 5008h set 5027h address data corresponding to content. Example: 1: 5000h address data = 0000h, 5001h address data = 0001h. Then the corresponding address 5014h ,5015h addresses are mapped to the content of 0000h, 0001h, according to the table, 5014h ,5015h address data for the frequency content high byte and low byte (Setting range 0 ~ 0x4c, read the corresponding region RS485 Data Sheet)
Client Custom 2	5001h	XX	1	0~76(0x4c)		R/W	0x0001h	
Client Custom 3	5002h	XX	1	0~76(0x4c)		R/W	0x0002h	
Client Custom 4	5003h	XX	1	0~76(0x4c)		R/W	0x0003h	
Client Custom 5	5004h	XX	1	0~76(0x4c)		R/W	0x0004h	
Client Custom 6	5005h	XX	1	0~76(0x4c)		R/W	0x0005h	
Client Custom 7	5006h	XX	1	0~76(0x4c)		R/W	0x0006h	
Client Custom 8	5007h	XX	1	0~76(0x4c)		R/W	0x0007h	
Client Custom 9	5008h	XX	1	0~76(0x4c)		R/W	0x0008h	
Client Custom 10	5009h	XX	1	0~76(0x4c)		R/W	0x0009h	
Client Custom 11	500Ah	XX	1	0~76(0x4c)		R/W	0x000Ah	
Client Custom 12	500Bh	XX	1	0~76(0x4c)		R/W	0x000Bh	
Client Custom 13	500Ch	XX	1	0~76(0x4c)		R/W	0x000Ch	
Client Custom 14	500Dh	XX	1	0~76(0x4c)		R/W	0x000Dh	
Client Custom 15	500Eh	XX	1	0~76(0x4c)		R/W	0x000Eh	
Client Custom 16	500Fh	XX	1	0~76(0x4c)		R/W	0x000Fh	
Client Custom 17	5010h	XX	1	0~76(0x4c)		R/W	0x0010h	
Client Custom 18	5011h	XX	1	0~76(0x4c)		R/W	0x0011h	
Client Custom 19	5012h	XX	1	0~76(0x4c)		R/W	0x0012h	
Client Custom 20	5013h	XX	1	0~76(0x4c)		R/W	0x0013h	
Custom the output 1	5014h		1			R		Meaning of the data subject 5000h~5013h address control, data format and the unit and the actual output data format to match the format, see the table RS485
Custom the output 2	5015h		1			R		
Custom the output 3	5016h		1			R		
Custom the output 4	5017h		1			R		
Custom the output 5	5018h		1			R		
Custom the output 6	5019h		1			R		
Custom the output 7	501Ah		1			R		
Custom the output 8	501Bh		1			R		
Custom the output 9	501Ch		1			R		
Custom the output 10	501Dh		1			R		
Custom the output 11	501Eh		1			R		
Custom the output 12	501Fh		1			R		
Custom the output 13	5020h		1			R		
Custom the output 14	5021h		1			R		
Custom the output 15	5022h		1			R		
Custom the output 16	5023h		1			R		
Custom the output 17	5024h		1			R		
Custom the output 18	5025h		1			R		
Custom the output 19	5026h		1			R		
Custom the output 20	5027h		1			R		

Floating data(Function code : 03h): (Additional data for V3.0 and above version)

Register Name	Address	Measurement range	Description	Default	R/W
FREQ	7000h	45.00~65.00Hz	Frequency		R
	7001h				
UA	7002h	0.0 ~1200000.0V	PhaseA voltage		R
	7003h				
UB	7004h	0.0 ~1200000.0V	PhaseB voltage		R
	7005h				
UC	7006h	0.0 ~1200000.0V	PhaseC voltage		R
	7007h				
ULN.AVG	7008h	0.0 ~1200000.0V	Average phase voltage		R
	7009h				
UAB	700Ah	0.0 ~1200000.0 V	PhaseA line voltage		R
	700Bh				
UBC	700Ch	0.0 ~1200000.0 V	PhaseB line voltage		R
	700Dh				
UCA	700Eh	0.0 ~1200000.0 V	PhaseC line voltage		R
	700Fh				
ULL.AVG	7010h	0.0 ~1200000.0 V	Average line voltage		R
	7011h				
IA	7012h	0.000~9999.000A	IA current		R
	7013h				
IB	7014h	0.000~9999.000A	IB current		R
	7015h				
IC	7016h	0.000~9999.000A	IC current		R
	7017h				
I.AVG	7018h	0.000~9999.000A	Average current		R
	7019h				
IN	701Ah	0.000~9999.000A	Neutral current		R
	701Bh				
P-A	701Ch	-999999999~999999999W	PhaseA active power		R
	701Dh				
P-B	701Eh	-999999999~999999999W	PhaseB active power		R
	701Fh				
P-C	7020h	-999999999~999999999W	PhaseC active power		R
	7021h				
P.SUM	7022h	-999999999~999999999W	Total active power		R
	7023h				
Q-A	7024h	-999999999~999999999VAR	PhaseA reactive power		R
	7025h				
Q-B	7026h	-999999999~999999999VAR	PhaseB reactive power		R
	7027h				
Q-C	7028h	-999999999~999999999VAR	PhaseC reactive power		R
	7029h				
Q.SUM	702Ah	-999999999~999999999VAR	Total reactive power		R
	702Bh				
S-A	702Ch	0~999999999VA	PhaseA apparent power		R
	702Dh				
S-B	702Eh	0~999999999VA	PhaseB apparent power		R
	702Fh				
S-C	7030h	0~999999999VA	PhaseC apparent power		R
	7031h				
S.SUM	7032h	0~999999999VA	Total apparent power		R
	7033h				
PFA	7034h	-0.020~+1.000~0.020	PhaseA power factor		R
	7035h				
PFB	7036h	-0.020~+1.000~0.020	PhaseB power factor		R
	7037h				
PFC	7038h	-0.020~+1.000~0.020	PhaseC power factor		R
	7039h				
PF.AVG	703Ah	-0.020~+1.000~0.020	Average Power Factor		R
	703Bh				
Reaserved	703Ch				R
	703Dh				
Reaserved	703Eh				R
	703Fh				
Load Type	7040h	R:82 L:76 C:67	R:Resistive L:Lnductive C:Capacitive		R
	7041h				

Register Name	Address	Measurement range	Description	Default	R/W
Reaserved	7042h				R
	7043h				
Reaserved	7044h				R
	7045h				
Reaserved	7046h				R
	7047h				
Reaserved	7048h				R
	7049h				
Reaserved	704Ah				R
	704Bh				
Reaserved	704Ch				R
	704Dh				
Reaserved	704Eh				R
	704Fh				
UA(UAB).THD	7050h	0.0~100.0%	UA(UAB) total harmonic of voltage		R
	7051h				
UB(UBC).THD	7052h	0.0~100.0%	UB(UBC) total harmonic of voltage		R
	7053h				
UC(UCA).THD	7054h	0.0~100.0%	UC(UCA) total harmonic of voltage		R
	7055h				
UAVG.THG	7056h	0.0~100.0%	Average total harmonic of voltage		R
	7057h				
IA.THG	7058h	0.0~100.0%	IA total harmonic of current		R
	7059h				
IB.THG	705Ah	0.0~100.0%	IB total harmonic of current		R
	705Bh				
IC.THG	705Ch	0.0~100.0%	IC total harmonic of current		R
	705Dh				
IAVG.THG	705Eh	0.0~100.0%	Average total harmonic of current		R
	705Fh				
Reaserved	7060h				R
	7061h				
Reaserved	7062h				R
	7063h				
AE-Total	7064h	0.0~99999999.9kWh	Total active energy		R
	7065h				
Reaserved	7066h				R
	7067h				
Reaserved	7068h				R
	7069h				
Reaserved	706Ah				R
	706Bh				
RE-Total	706Ch	0.0~99999999.9kVARh	Total reactive energy		R
	706Dh				
Reaserved	706Eh				R
	706Fh				
Reaserved	7070h				R
	7071h				
CO ₂	7072h	0.000~999999.999kg	Total CO ₂ weight of energy		R
	7073h				