

DESCRIPTION

CPM-10 Multifunction Power meter measure single phase 2 wire ,single phase 3 wire ,three phase 3 Wire and 3 Phase 4 wire systems with high accuracy measurement for parameters such as voltage, current ,active power, reactive power, apparent power, power factor ,frequency, effective energy (V,A,W,Watt-Hr,Var,Var-Hr,VA,PF ,Hz), having LED display and standard communication RTU Modbus RS485..

Optional functions 1 set relay output,1 analogue,1 RS485 (ModbusRTU Mode) or 1 pulse output. Most suitable for power management,remote input /output, alarm and remote signal control uses needs.

Case depth 120mm only, easy panel mounting installation

FEATURE

- Measure 1P2W,1P3W,3P3W,3P4W Unbalanced/Balanced load system's active power, reactive power, apparent power and electric energy (Watts-Hr) etc parameters.
- Dual display, upper row 4 digits and voltage/ 4 digits for current (or 10 digits Watts-Hr),lower row 4 1/2 digits Watts. (0~29999)
- 1 set relay(SPDT) output, with 3 variable setting (R1.1/R1.2/R1.3), can be set to below parameters V.AVG/I.AVG/FREQ/P.TL/Q.TL/ S.TL / PF.AVG / AE.TL / RE.TL / VA / VB / VC / IA / IB / IC / PF-A / PF-B / PF-C / P-A / P-B / P-C / Q-A / Q-B / Q-C / S-A / S-B / S-C, having relay function : Hi / Lo / Hi Hold / Lo Hold / OFF; further advance function , start delay, hysteresis, time delay, reset delay etc
- 1 analogue output same as relay setting parameters. Selectable output range for voltage or currents
 - Output ranges for Current 0~10mA / 0~20 mA / 4~20 mA / 4~±20 mA / ±10 mA / ±20 mA (Default 4-20mA)
 - Output ranges for Voltage 0~5V / 1~5 V / 0~10 V / 0~±5 V / 1~±5 V / 0~±10 V / ±5 V / ±10 V (Default 0-10V)
- Option pulse or RS 485 communication output.
- Outer case standard DIN 96 x 48 mm
- CE approved

Application

Motor control/ panel power monitoring/power consumption monitor and control/power distribution system /intelligent building & automation power management system/ power testing equipment



ORDERING INFORMATION

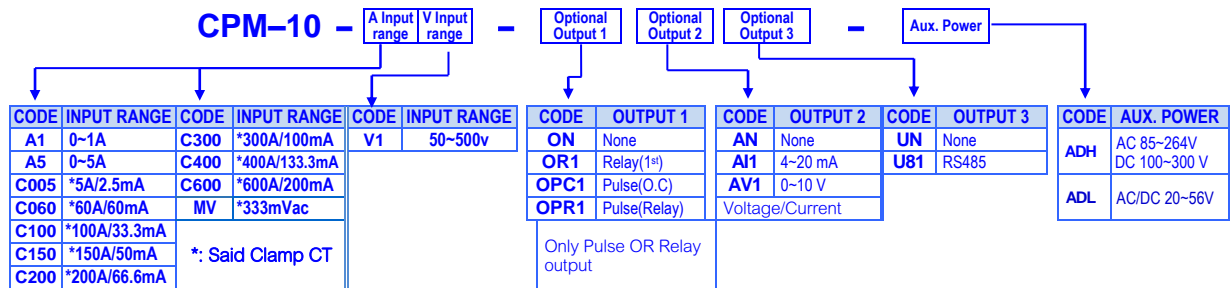

TECHNICAL SPECIFICATION

Measurement and connection

Connection	Input range			Input consumption
	Voltage	Amp.	Freq.	
1P2W	50~500Vac(VL-N)	1A 5A	45~65 Hz	Voltage:≤0.5VA/Phase or Current:≤0.1VA/Phase
1P3W				
3P3W				
3P4W				

* Max input 500V, 5A, if exceed please use PT or CT

Accuracy and resolution (Accuracy add 1.0 % when selected the Clamp Type)

Parameters	Accuracy	Max. Resolution	Display Range
Voltage	0.2%	0.1 V	0~2999.9
Current	0.2%	0.02 A	0~2999.9
Active	0.5%	0.001 kW	-19999~29999
Reactive	0.5%	0.001 kVar	-19999~29999
Apparent	0.5%	0.001 kVA	-19999~29999
Power factor	0.5%	0.001	-0.020~1.000~+0.020
Frequency	0.2%	0.01 Hz	45.00~65.00
Effective	0.5%	0.001 kWh	0~999999999
Ineffective	0.5%	0.001 kVarh	0~999999999

Input

Measurement: True RMS Value
 Ripple effect: ≤ 0.2% of F.S. at 30% distortion
 A/D converter: 16 bits A/D converter

Sampling rate: 128point/Cycle
 Response time: ≤100 ms (Average value set as "1")
 System: 1P2W, 1P3W, 3P3W, 3P4W;
 Unbalanced / Balanced load
 Input range: **Voltage: 50~500V L-N**
 Primary shunt unit setting: V and KV
 PT Primary setting: 50.0V~100KV
 PT Secondary setting:50.0~500.0V
 Direct Input: Primary = Secondary < 500V
Current: 0 ~ 1/ ~ 5A (max.)
 CT Primary setting: 1~2999.9A
 CT Secondary setting: 1.000~5.000A (Option)
Frequency: 50/60Hz ± 3Hz,

Max. input capability:

Voltage: 2 X rated voltage continuous
 4 X rated voltage continuous 2 minutes
Current: 3 X rated current continuous
 10 X rated current continuous 10 seconds
 50 X rated current 1 second (5A input type)

Control function

Setting point: 3 sets (1 contact output for 3 set values)
Relay output: 1set SPDT, 5A/230Vac, 5A/115V
Relay settings: Up to 27 parameters relay setting
Relay mode: Hi / Lo / Hi.HLd / Lo.HLd / OFF
Function: Start delay/Start band/ Hysteresis /Relay hold

Start band: 0~9999 counts
 Start delay: 0:00.0~9(Minutes):59.9(Second)
 Run delay: 0:00.0~9(Minutes):59.9(Second)
 Off delay: 0:00.0~9(Minutes):59.9(Second)
 Hysteresis: 0~5000 counts

Analogue(Optional)

Accuracy: $\pm 0.1\%$ of F.S.; 16 bits DA converter
 Ripples: $\leq \pm 0.1\%$ of F.S.
 Response time: ≤ 100 m-sec. (Input range 10~90%)
 Isolation: 1500V between input and output
 Output range: [Ra5L] **Voltage:** 0~5V / 0~10V(Default) / 1~5V / 0~2.5~5V / 1~3~5V / 0~5~10V / -5~+5V / -10~+10V
Current: 0~10mA / 0~20mA / 4~20mA(Default) / 4~12~20 mA / -10~10 mA / -20~+20 mA

Output load capability: **Voltage output:** 0~10V $\geq 1000\Omega$
Current output: (0)4~20mA $\leq 530\Omega$
 Function: [RaHS] Maximum output value display setting
 Setting range: -19999~29999
 [RaL5] Minimum output value display setting
 Setting range: -19999~29999
 [RaLnt] (Output Hi): Output from 0.00~110.00%
 [RaPro] Setting range: -32768~+32767
 [Ra5Pn]: Setting range: -32768~+32767

Digital adjustment:

RS 485 (Optional)

Protocol: Modbus RTU mode
 Baud rate: 1200/2400/4800/9600/19200/38400 bps selectable
 Bits: 8 bits
 Parity check: Odd \ even or none (with 1 or 2 stop bit) selectable
 Address: 1 ~ 255 selectable
 Wire distance: 1200M max
 Terminal resistance: 150 Ω .

Pulse output(Optional)

Output mode: 1 channel open collector \ DC 30V/100mA
 Output parameters: Effective energy : (AE.TL / -AE.TL)
 Ineffective energy : (RE.TL /-RE.TL)
 Max frequency: 1000Hz ; duty cycle 50%
 Pulse/Count: 1 Pulse/1~9999 Count selectable.

Power supply

Working voltage: ADH:AC 85~264V \ DC 100~300V
 ADL:AC/DC 20~56V
 Power consumption: AC Power $\leq 12VA$, DC Power $\leq 6W$
 Data storing: By EEPROM

Safety

Insulation: AC 2.0 KV for 1 min, Power/Input/Output/Casing
 Isolation resistance: $\geq 100M$ ohm at 500Vdc, Power/Input/Output/Casing
 Signal isolation: Power/Input/Relay/RS485/Analogue output/Pulse
 EMC: EN 61326-1:2006
 EN61000-3-2:2006+A1:2009+A2:2009
 EN61000-3-3:2008
 EN 61010-1:2001

LVD:

Working environment

Temperature.: 0~60 °C
 Humidity(%RH): 20~95 %RH, Non condensing
 Temp. coefficient: ≤ 100 PPM/°C
 Storage: -10~70 °C
 Protection: Front panel: IEC 529 (IP52); Case: IP30

Mechanical

Dimension: 96mm(W) x 48mm(H) x 120mm(D)
 Mounting size: 92mm(W) x 44mm(H)
 Case material: ABS Non-flammable (UL 94V-0)
 Installation: Panel mounting
 Terminal: Plastic NYLON 66 (UL 94V-0)
 10A 300Vac, M2.6, 16~22AWG
 Weight: 350g(Aux. Power : ADH, ADL)

Front panel

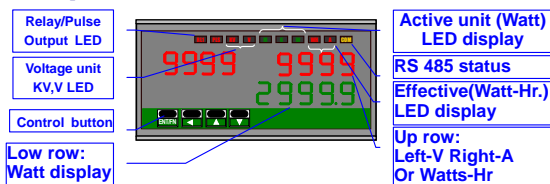

Display:

Low row: 5 Digits; 0.28"(0.71cm) Green LED (Watt)
Up row: 10 Digits; 0.28"(0.71cm) Red LED
Selection [d 5.5L]: **When[u-R]:** Left \ right each 4 Digits(V/A)
When[L-H]: 10 Digits totalizer (Watts-Hr)
Active power: 3 green rectangular LED for W / KW
 Effective : 3 rectangular red LED for Wh / KWh / MWh

I/O Status:

PLS Pulse output display: 1 rectangular red LED
 During pulse transmission, LED will blink ; when it blink faster mean Watt-Hr. accumulate more
COM RS 485 communication: 1 rectangular orange LED
 RS485 signal send/receive data \ LED will blink
 When**COM**blink faster, data transfer speed is higher
RL1 Relay output LED:1 rectangular red LED
 LED on when relay output;;

Control button:

4 control buttons: Enter, function./ Shift / Up / Down
Up key: Value increase / return to previous level
Down key: Value decrease / enter next level
Shift key: Move decimal point / return to up level / escape setting
Enter/Func key: Enter setting status / save and enter next function parameters

Password function:

4 digits password setting ; range 0000~9999
 Password for parameters setting level needed.
 Password can be change at parameters level
 Please contact us if password lost.

Lock function:

4 lock modes, No lock/User level lock/Parameters Setting lock/Lock all
None: No lock \ all function and parameters selectable
User Level: Open for viewing level, not able to change any setting if locked
Engineer Level: Open for viewing level, not able to change any setting if locked
All: Locked all level.

Casing dimension

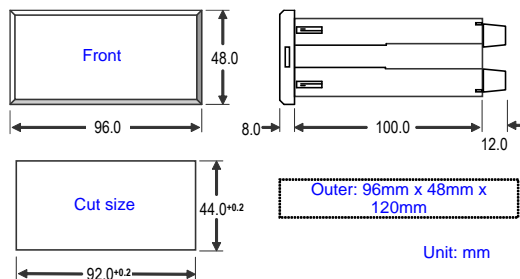

Installation

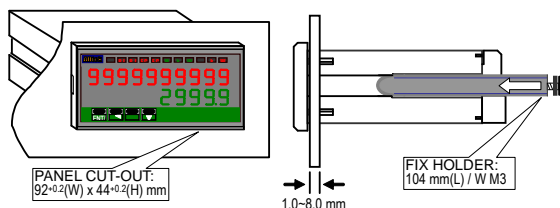

Please install meter within working temperature & humidity environment

Wiring diagram

Please check input operating voltage before sending power, terminal connection to right number. Advise adding fuse/switch in front of power.

RS485 / Pulse / Relay wiring: AWG22~16(0.5~1.3mm²)
Other: Wiring: AWG15~10(1.5~2.5mm²)

Operating power connection

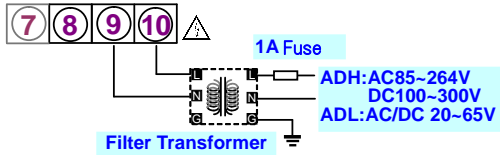

Input connection

1 Phase 2 wire (Unbalanced load) ■With CLAMP CT, do not ground or parallel connection the secondary side, otherwise the header burned

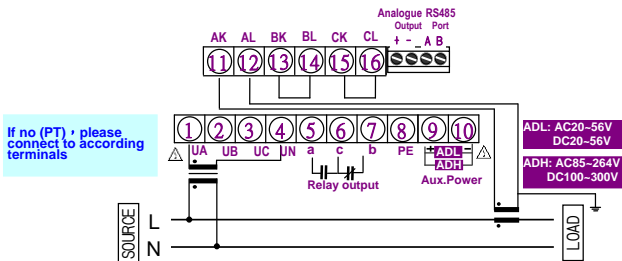

1 Phase 3 wire(Unbalanced load) ■With CLAMP CT, do not ground or parallel connection the secondary side, otherwise the header burned

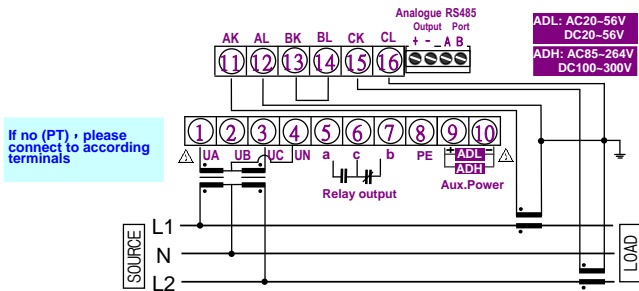

3 Phase 3 wire(Unbalanced load 2CT) ■With CLAMP CT, do not ground or parallel connection the secondary side, otherwise the header burned

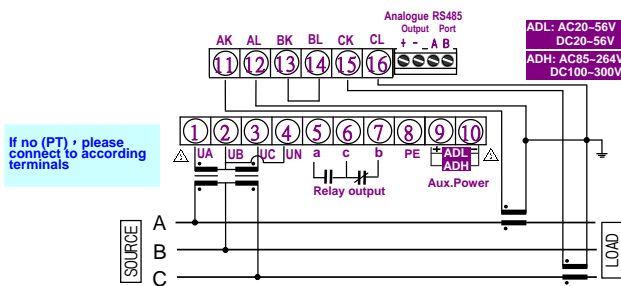

3 Phase 3 wire(Unbalanced load 3CT) ■With CLAMP CT, do not ground or parallel connection the secondary side, otherwise the header burned

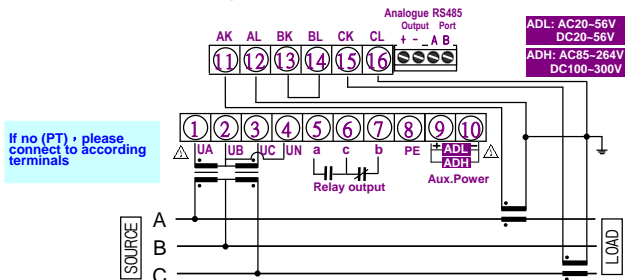

3 Phase 3 wire(Balanced load 1CT)

■With CLAMP CT, do not ground or parallel connection the secondary side otherwise the header burned

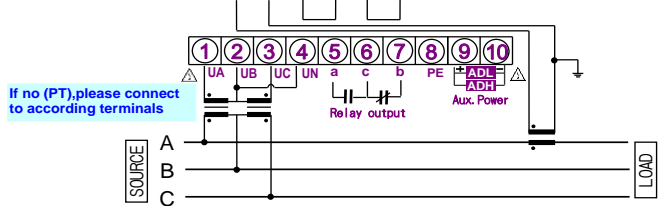

3 Phase 4 wire(Unbalanced load 3CT)

■With CLAMP CT, do not ground or parallel connection the secondary side, otherwise the header burned

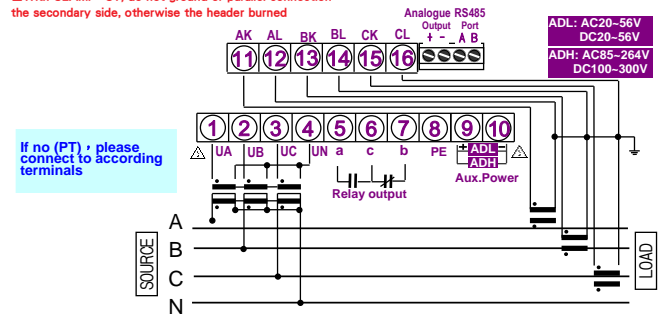

3 Phase 4 wire(Balanced load 1CT)

■With CLAMP CT, do not ground or parallel connection the secondary side, otherwise the header burned

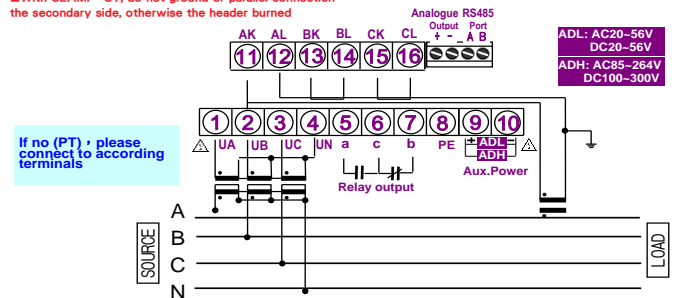

Output signal connection

Due to limited terminals, pulse and relay output is using same terminal, only 1 output is available, will not have both. Please follow product code, specification on label and connection according to given on product

RS485 output

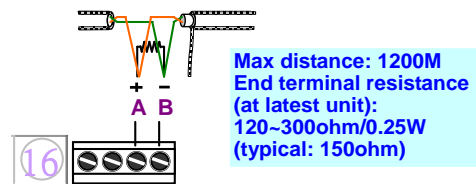

Pulse output

Open collector output:

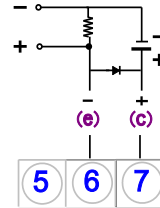

Relay output:

Contact load 5A/230V, 5A/115V

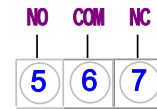

Analogue output

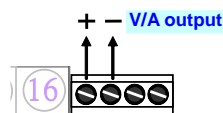

1 Analogue + RS485 Output

